



Peczuh Printing now offers Folding Carton Services.

Our equipment is designed to print, cut, glue
and convert almost any type of folding carton.

We encourage you to familiarize yourself with folding carton
styles used both in automation and manual assembly.

How to Measure a Folding Carton

There are three dimensions to the basic folding carton: Length (L), Width (W), and Height (H). In written form the dimensions should appear in that order (L x W x H).

Use the figure of this reverse tuck carton below to match each of the dimensions up with its corresponding panel:

L= dimension from left to right (commonly the front and back panels)

W = dimension of the side panels (commonly measured from the front to the back)

H = dimension from bottom to top (total height from the bottom to the lid, not including closure)

When determining the size of a folding carton, be sure to measure from the middle of the score. To ensure accuracy, measurements should be taken to 1/16".

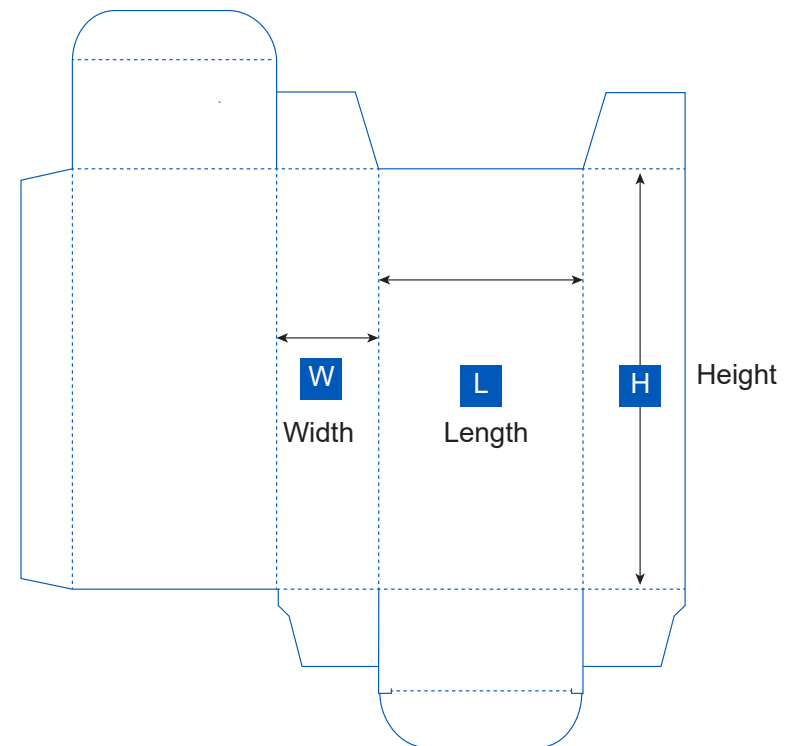
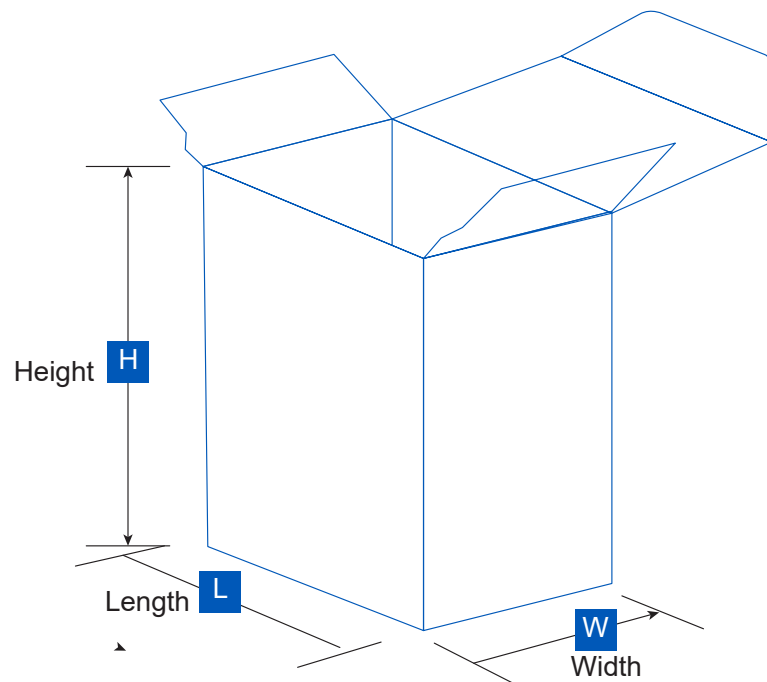

Measuring a Tray Box

As with basic tuck cartons, there are three dimensions that create basic folding trays: Length (L), width (W), and height (H). In written form the dimensions should appear in that order (L x W x H).

Refer to the figure of the rolled edge tray below to correctly identify and label panel dimensions:

L= dimension from left to right (commonly the front and back panels)

W = dimension of the side panels (commonly measured from front to back)

H = dimension from bottom to top (total height from the bottom to the lid, not including the closure)

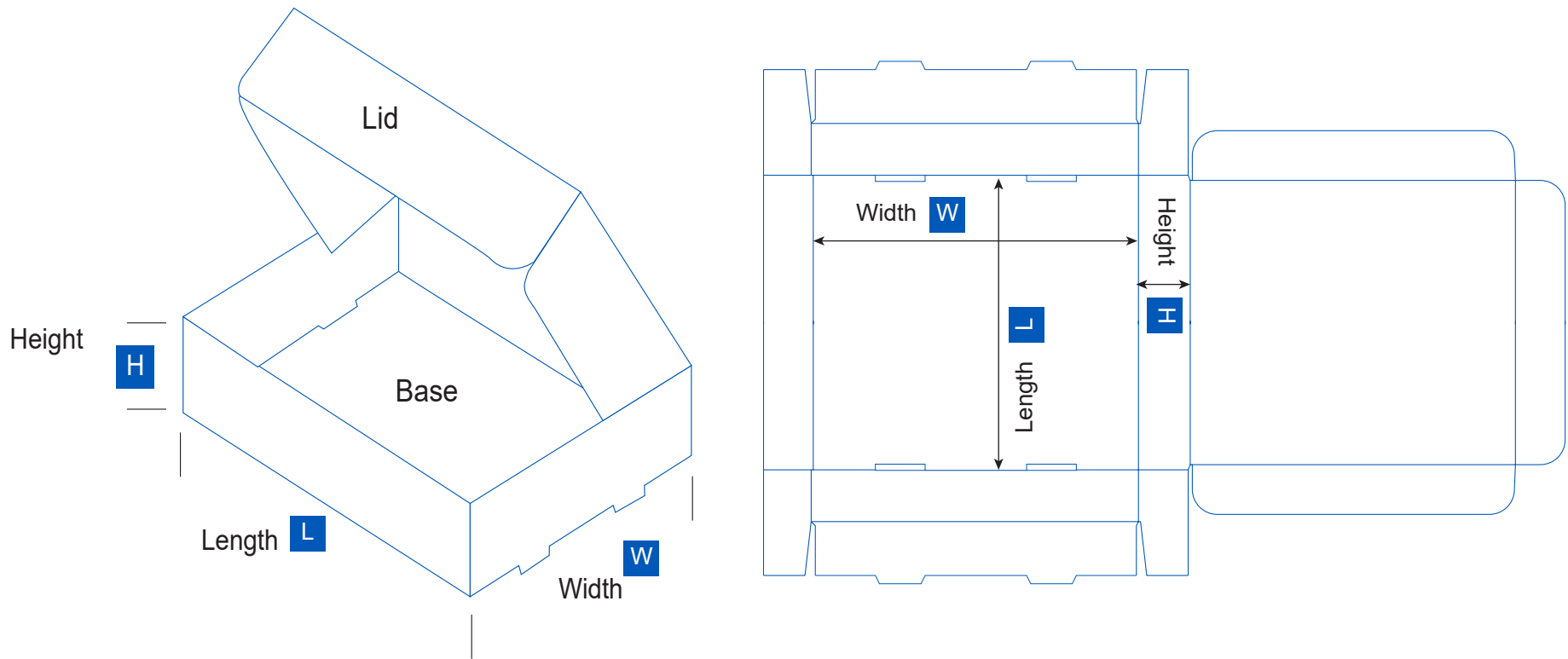

Straight Tuck End (STE)

This style allows for a maximum uninterrupted display panel on the front of the box. The closures and raw edges occur on the back of the box. The Straight Tuck End, also known as a Standard Straight Tuck (SST) allows for placement of a window if desired without interference from the tuck flaps as shown below.

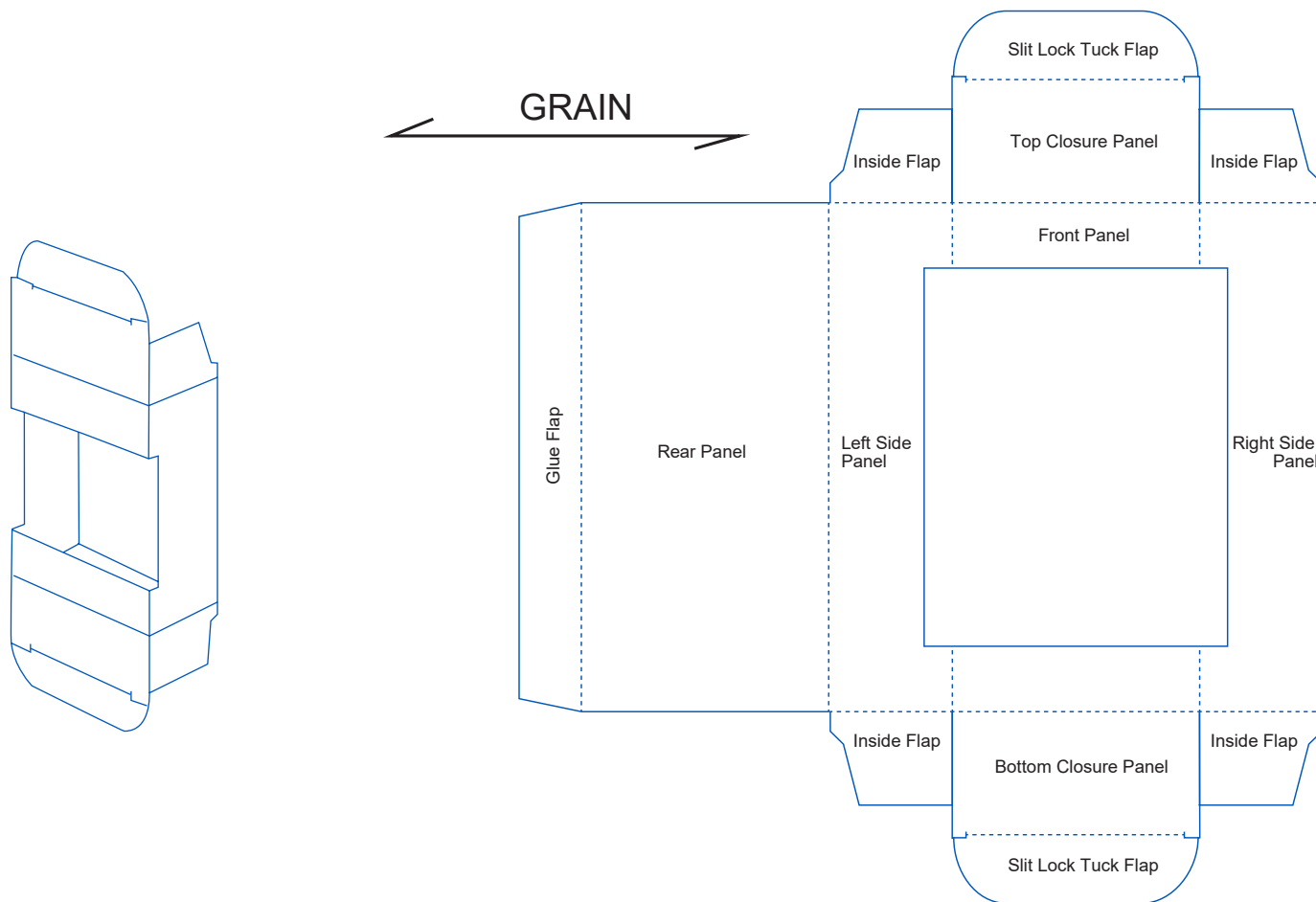

Standard Reverse Tuck (SRT)

This style is very similar to the Straight Tuck End, except closure panels on the Standard Reverse Tuck swing in opposite directions. With a friction lock closure on the top and a slit lock closure on the bottom, this carton is easy to open and close, while remaining unlikely to inadvertently open at its base.

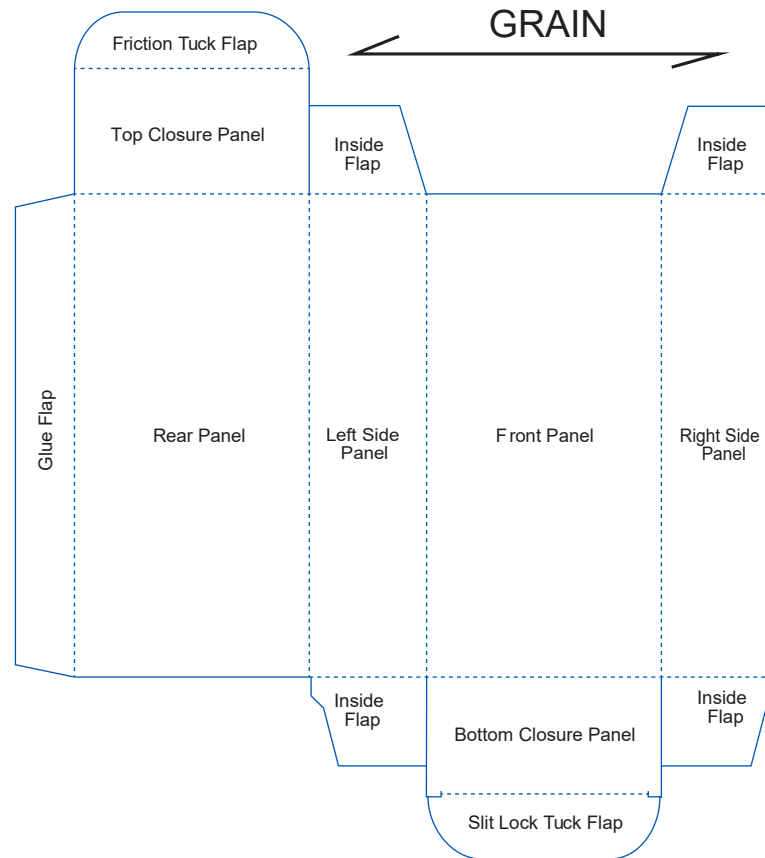
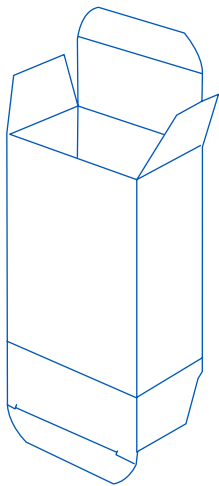

Snap Lock Bottom

This popular closure is also commonly known as a 1-2-3 Bottom. This is usually paired with a tuck top closure, and requires manual assembly.

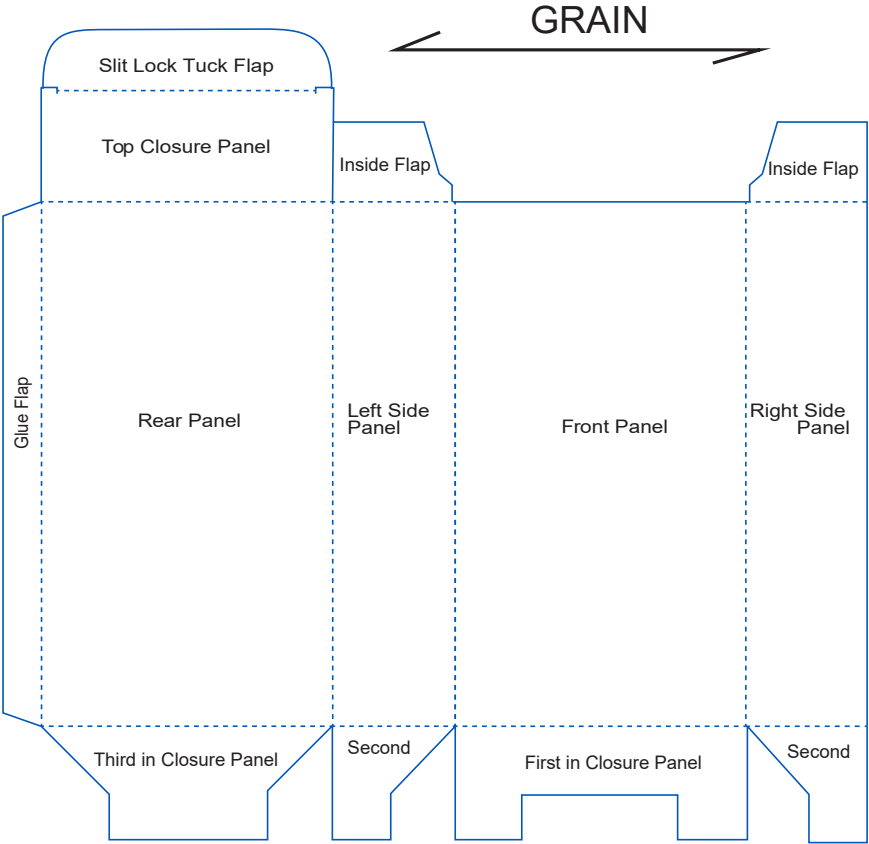
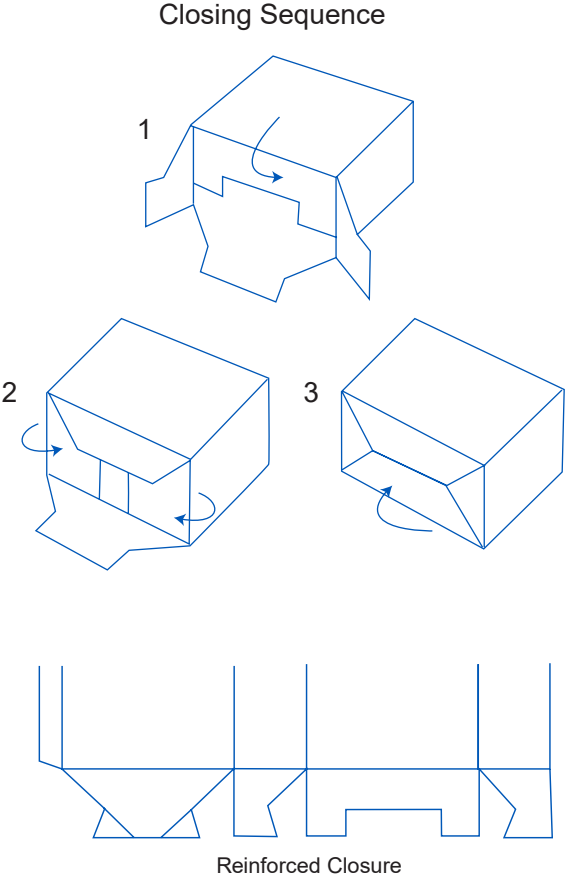

Auto-Bottom

This common closure is glued at the box converter and “automatically” assembles as the box is erected. Also known as a “Crash Lock Bottom”, this is a sturdy closure that allows quick and easy set up.

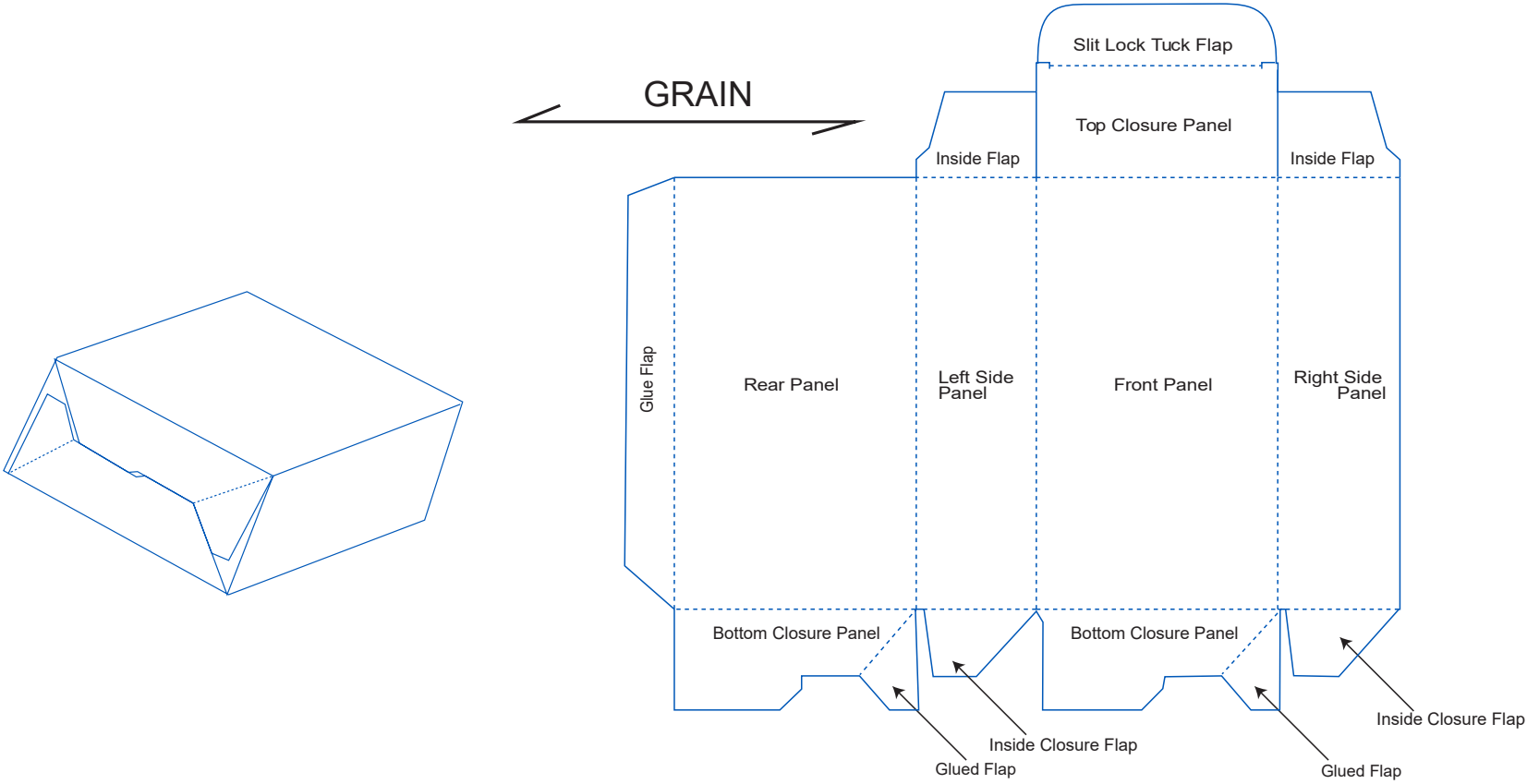

Full Overlap Seal End (FOSE) & Partial Overlap Sealed End (POSE)

These styles are typically erected, fulfilled, and sealed on automated packaging equipment. While the FOSE incorporates an outer end panel that covers the entire end of the box, the POSE style features closure panels that overlap just enough to accommodate an adhesive seal. The POSE is often paired with the ever-popular “Tuck Tab” closure—think of a cereal box-top closure.

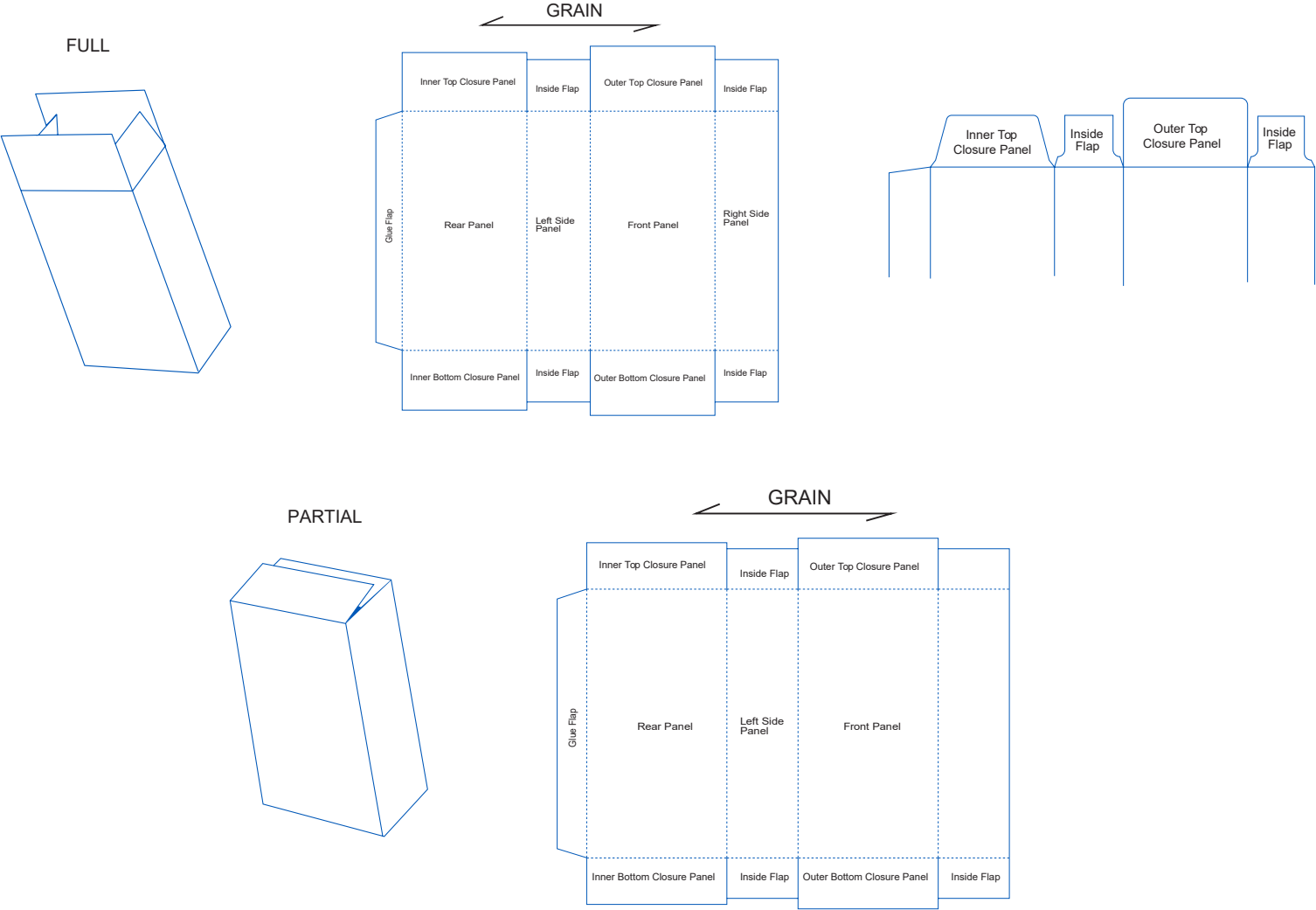

PECZUH

PRINTING & PAPERBOX

The next few pages are POPULAR STYLES & OPTIONS for paperboard packaging.

They include:

Counter Top Displays, Pillow Packs, Self-Mailers, Hanging Headers, Display Windows,
Security Features, Integrated Inserts, Sleeves & Enclosures, Envelopes & Mailers,
Dispensers, Totes, and Custom Designs...

If you can imagine it we can make it!

Tuck and Tongue

This style is generally assembled, filled and sealed manually. The Tuck and Tongue carton is designed to withstand rough handling without disengaging.

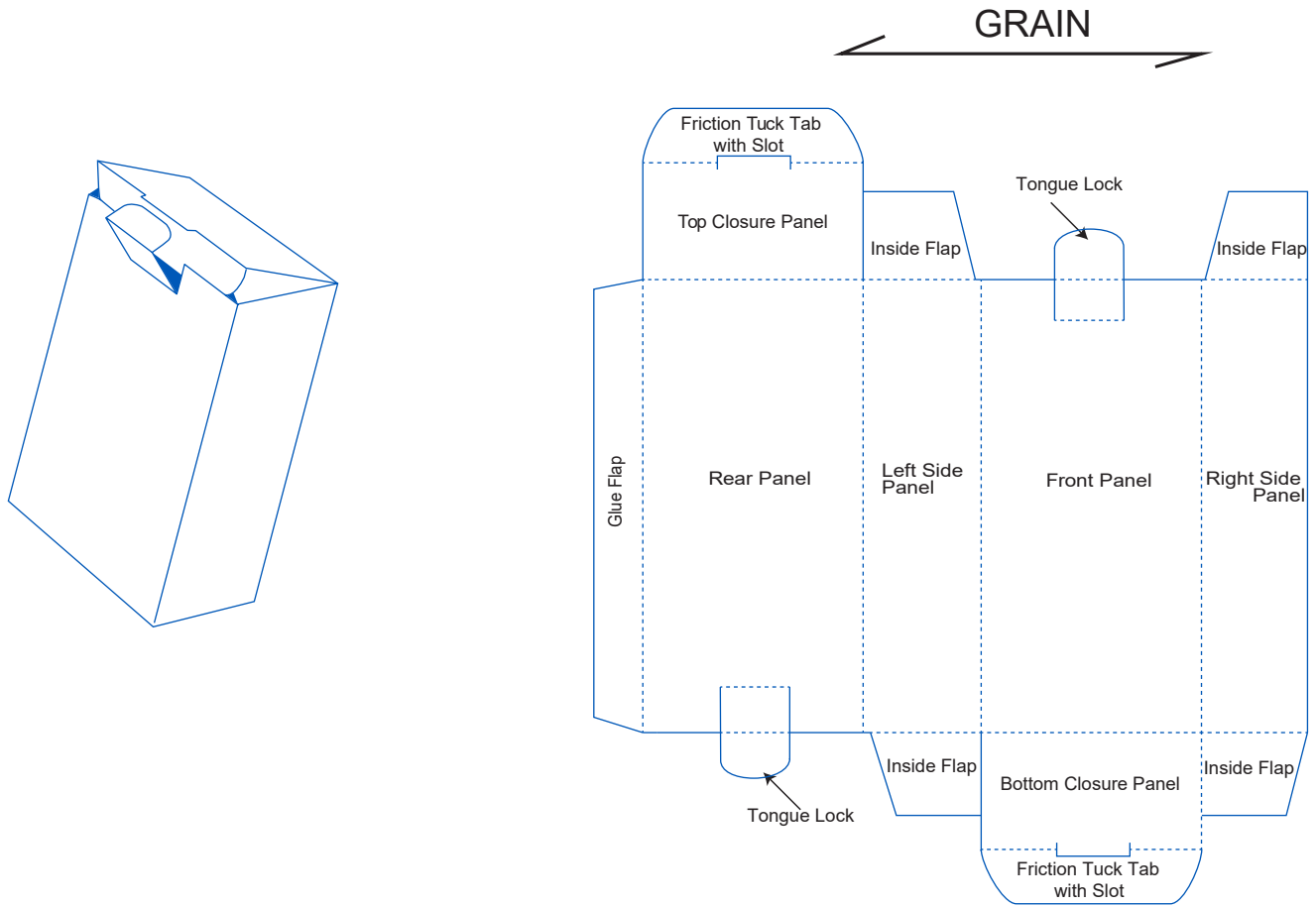

Folding carton with Integrated Separator

The digital folding carton with integrated separator is designed to create a barrier between separate packaged components. It includes a structure of division formed by one or several panels, each having a perpendicular flap in every extremity of that panel so as to adhere to the internal surface of the walls of the carton. We arrange these transverse panels by means of grooves, which form one or several compartment.

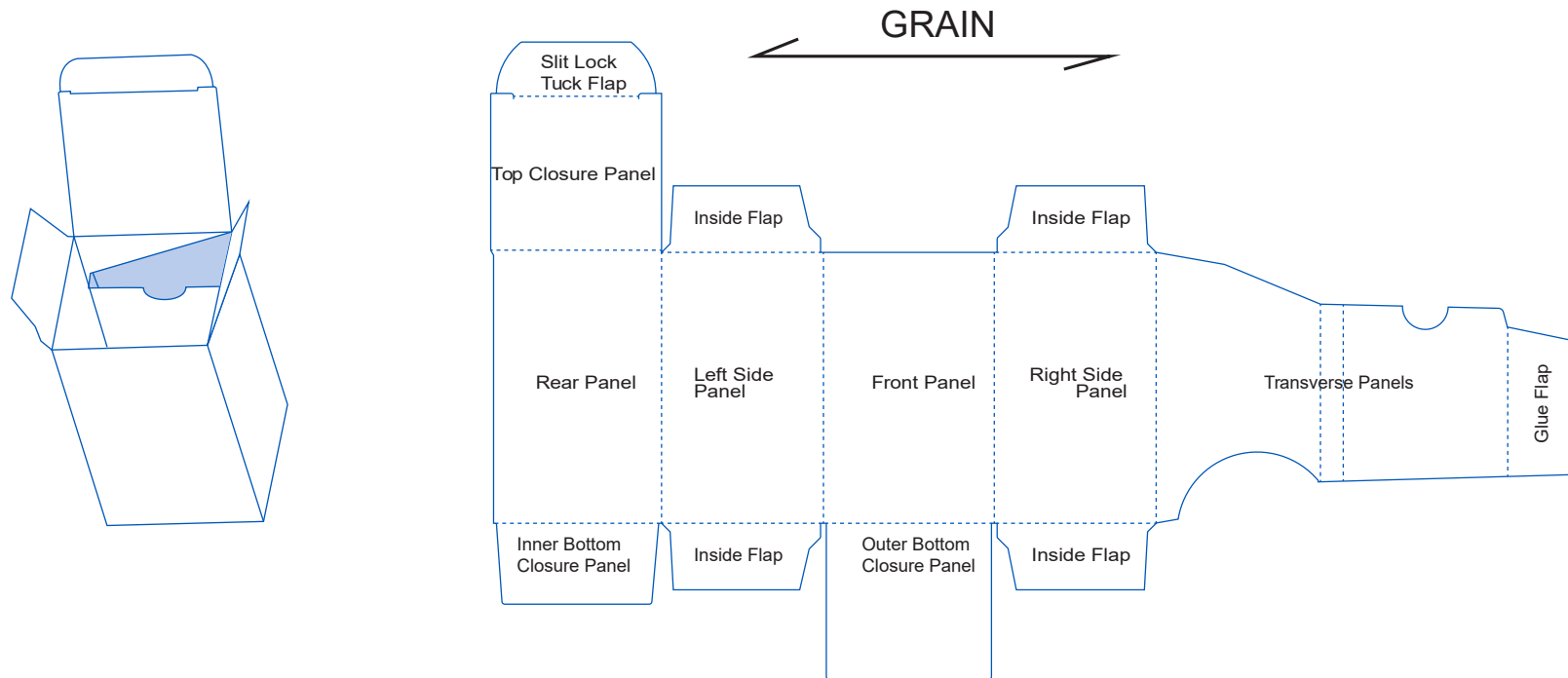

Dispenser Style Carton (1 piece)

The dispenser style carton is often used on the counter near a cash register to stimulate sales. Used by the retail and the food sector, it's often a staple of the medical and pharmaceutical industry.

In the illustrated model, the fall open part is integrated in the carton what makes the opening and closing possible. If the fall open part is not integrated, the opening and closure will be more difficult (*see next page*).

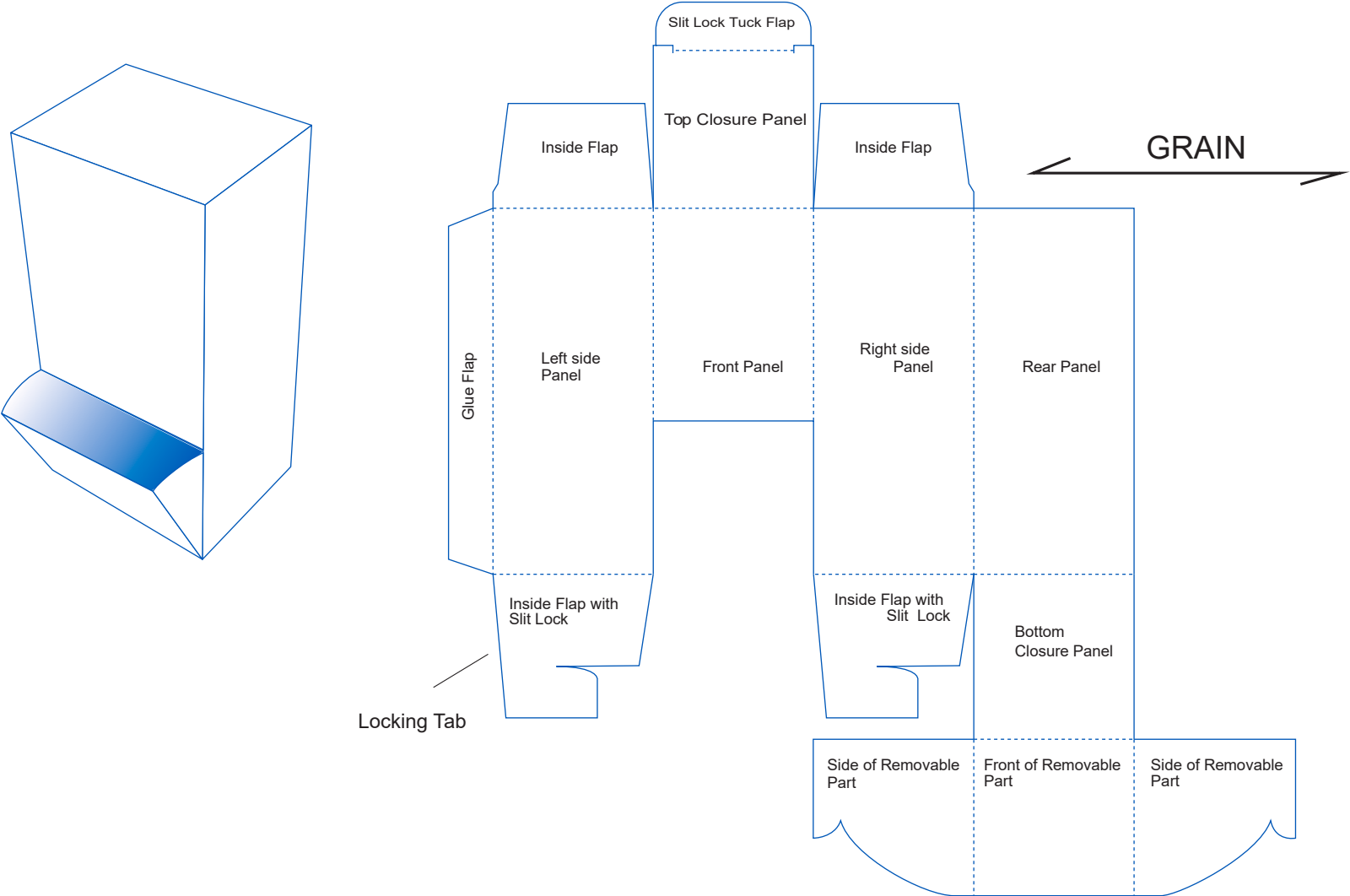

Dispenser Style Carton (2 pieces)

These dispenser style cartons have the ability to conveniently pour out contents quickly and easily.

Frequently used in conjunction with auto bottom structures, these cartons feature a distinctive design that offers a number of benefits. One of these advantages: a bottom which can be formed automatically for fast packaging. Also, the flat bottom and body of this carton save space of storing.

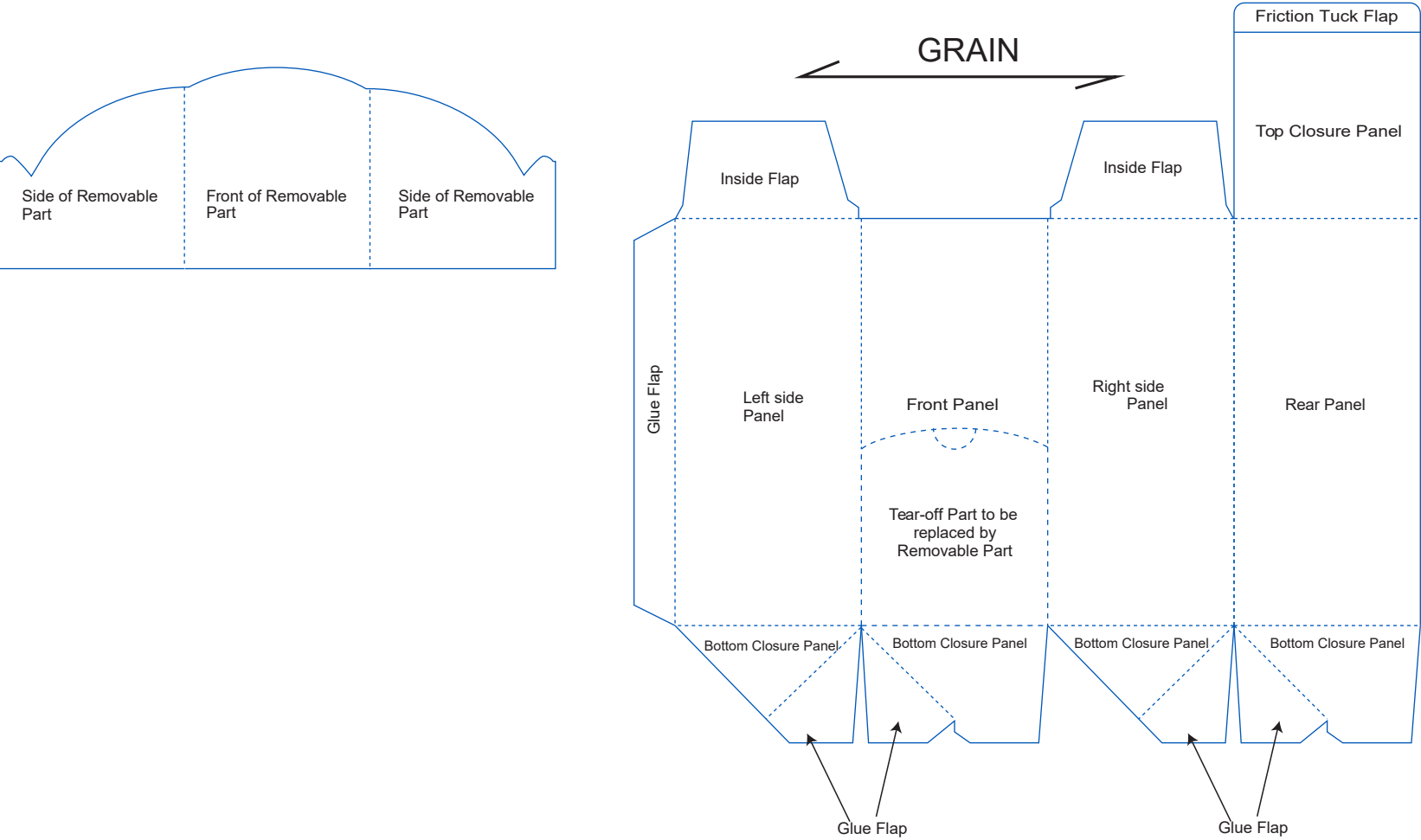

Counter Display

A Counter Display Carton is designed to provide a point-of-purchase unit for holding a number of individual packages or products.

It does not need to be glued. The retailer simply opens the top of the carton and folds the lid back for easy advertising. The front panel as well as the inside flaps can be torn-off so visibility is easier and accessibility to the product is improved.

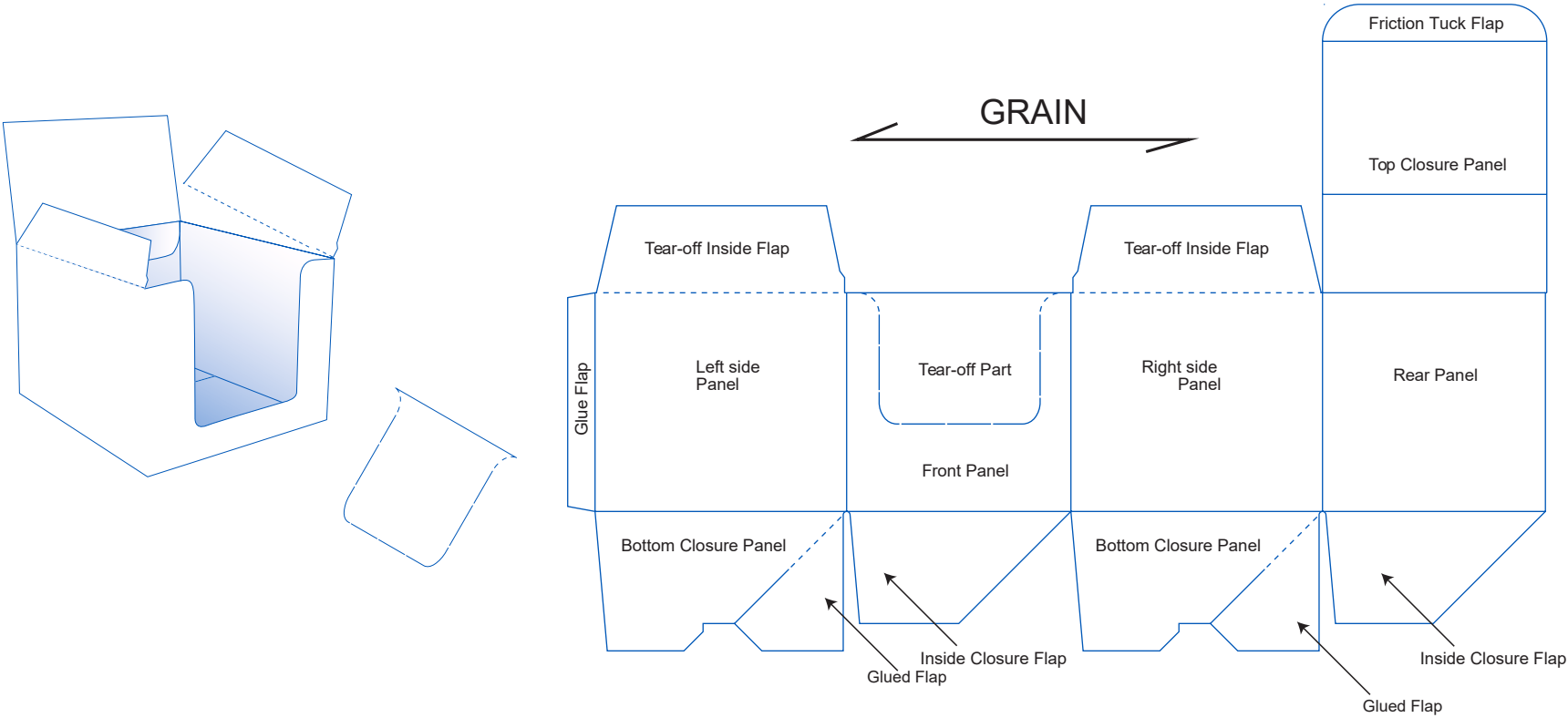

Standard Straight Tuck (SST) with Hanger Tab

The SST with Hanger Tab carton is used for small and light products. It is an ideal stand-alone package to be placed on a hook.

A perforated panel (perfs here called notches) with a fold will be added to the back panel. When the panel is folded up, notches are generally aligned and the front panel sealed to the back panel to create and secure the hanger tab. A window can be added on the front panel for better visibility of the product.

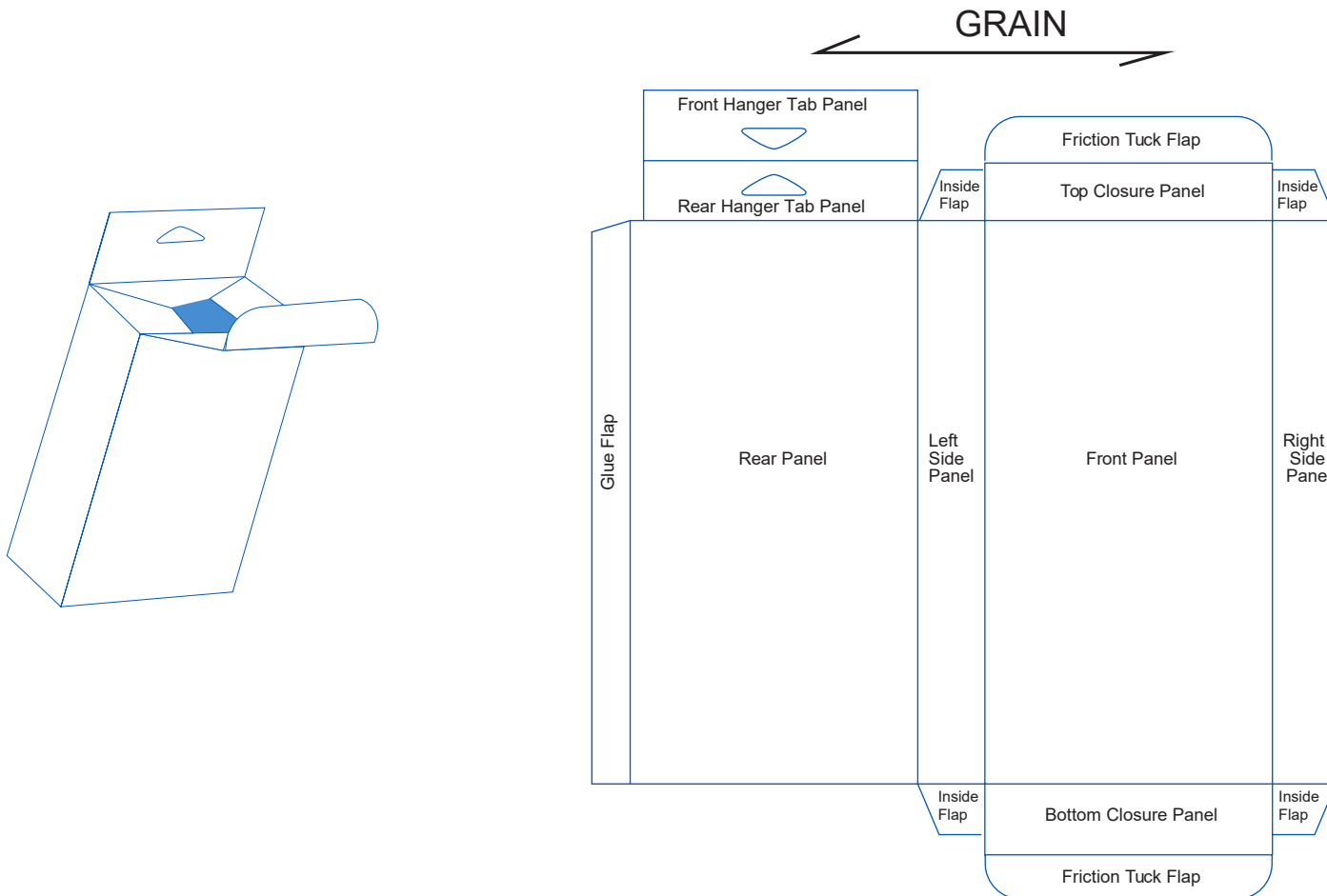

Overlap Seal End with Side Hanger Tab

This carton style, also called the “5 panel carton”, is often used to develop a header panel. The structure also includes a rear card with a hang tab notch which allows the card to be used as a hanger tab.

Style B: this carton has a hanger panel that can be folded up on one of the sides of the carton, can be assembled, filled and sealed on automated packaging equipment. The order for the closure is the same as that of a regular overlap carton.

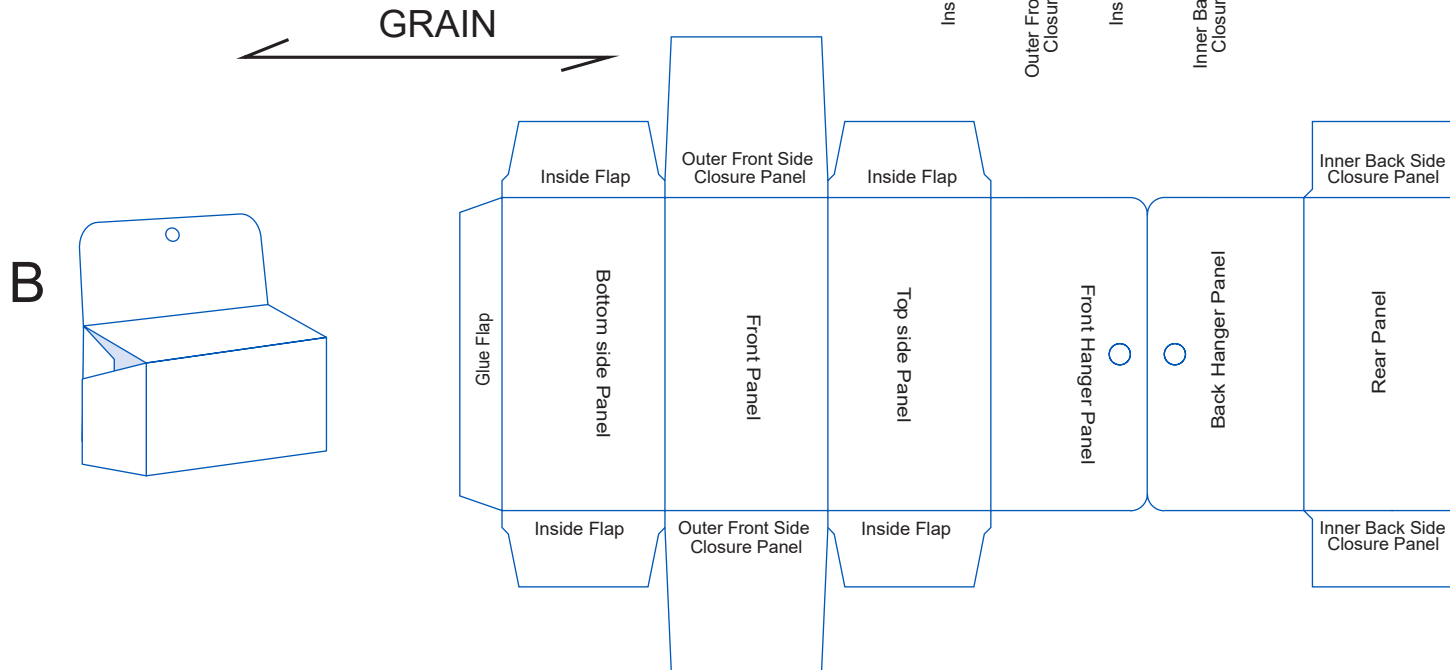
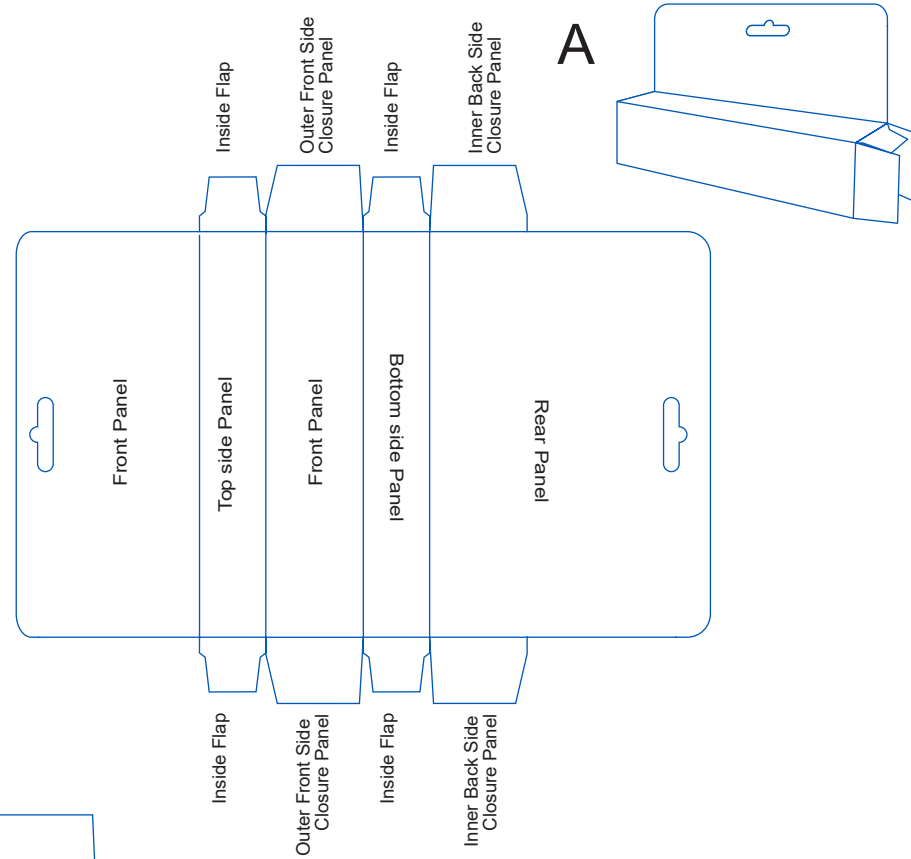

Bag Carton with Snap-Lock Bottom

The Bag Carton with 1-2-3 Bottom is primarily used for custom cosmetic cartons and custom food cartons. It can be made with an Auto Bottom, glued on the bottom by the cartons manufacturer and allows for quick loading.

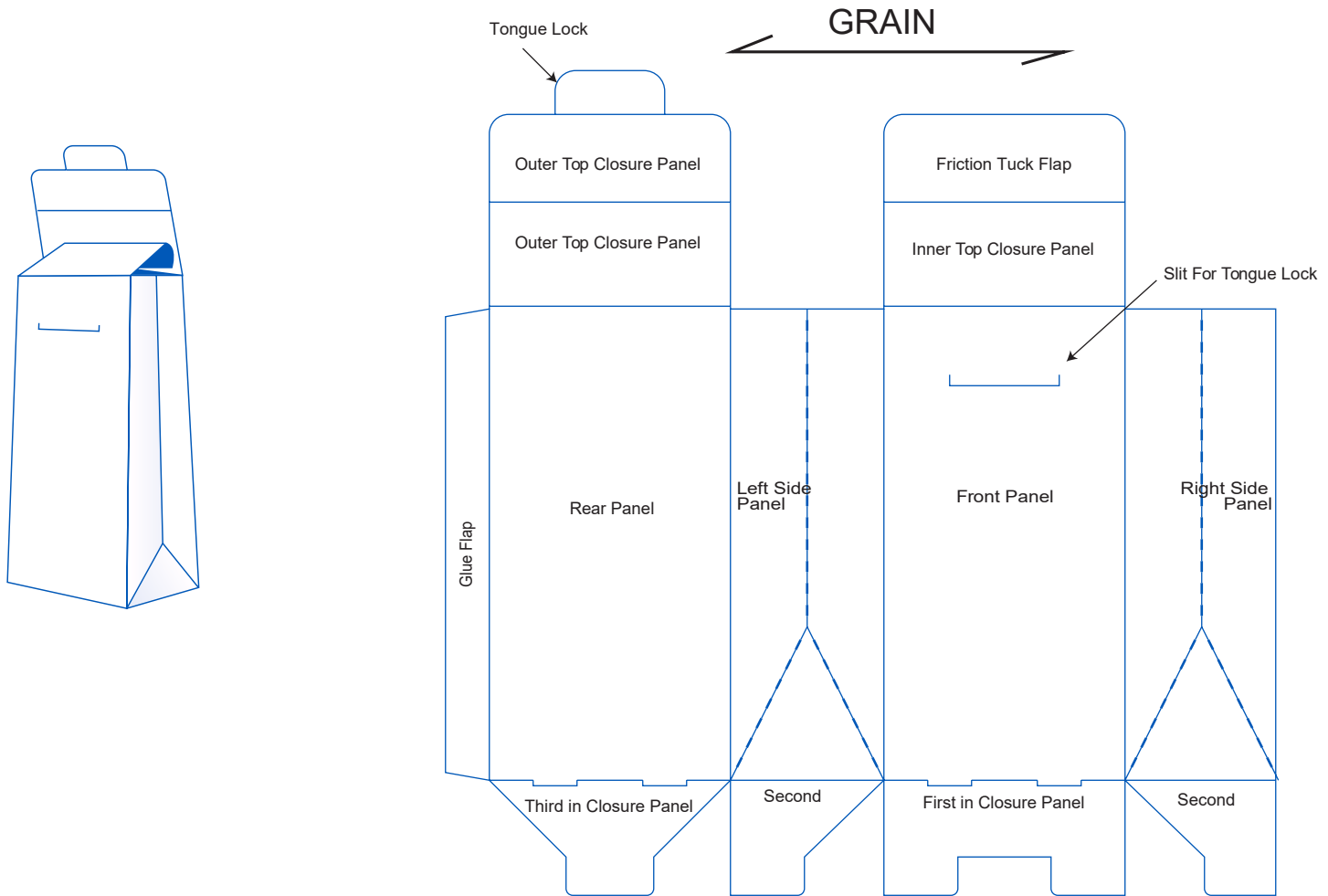

Sleeve

The Sleeve is a tubular form, usually opened at both ends, and made in various shapes, which is then slipped over an item. This style can be used as a decorative cover or to offer protection for the product.

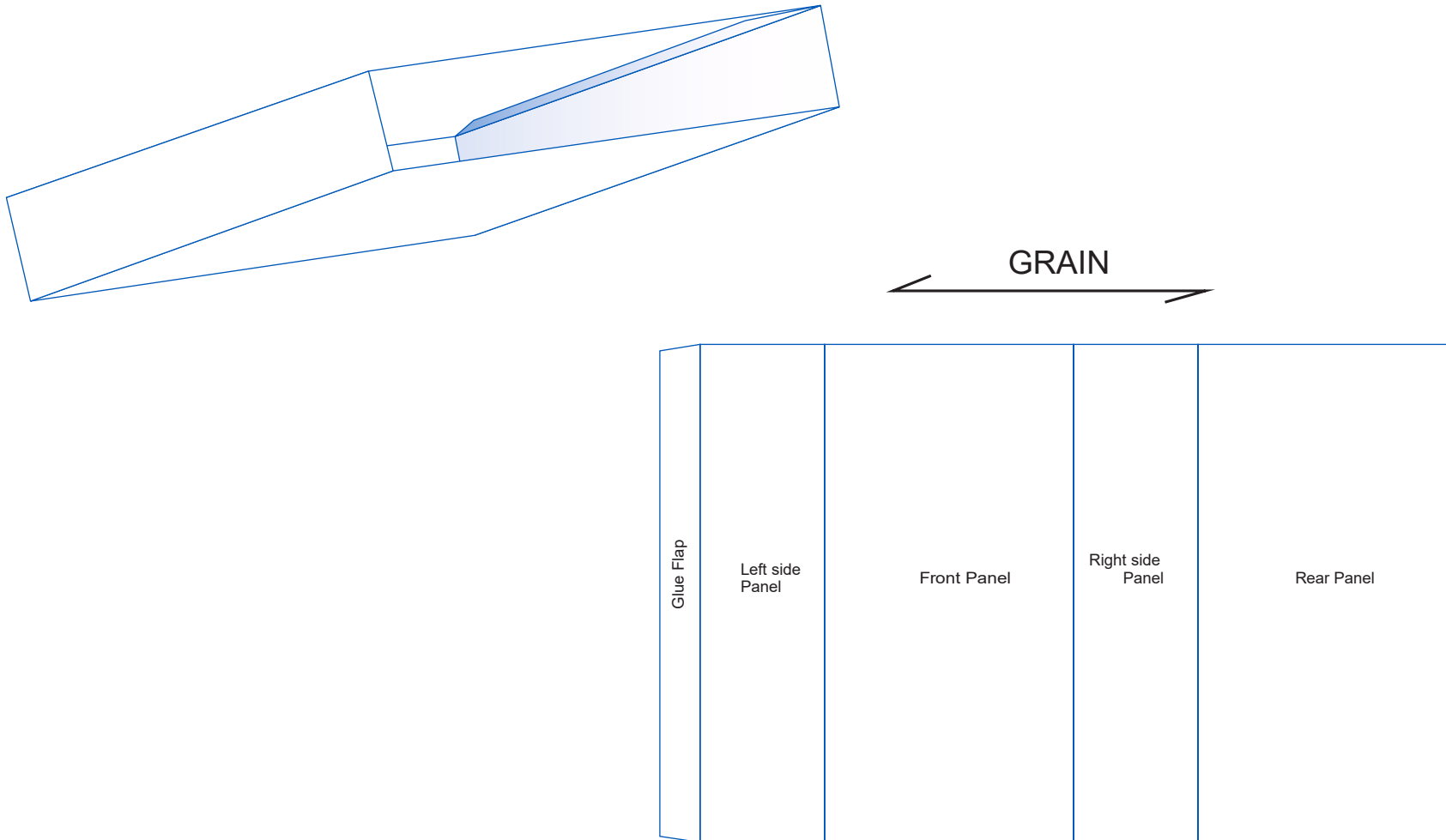

Pillow Box

A pillow carton is a unique shape and is used for custom cosmetic cartons, candy cartons and more.

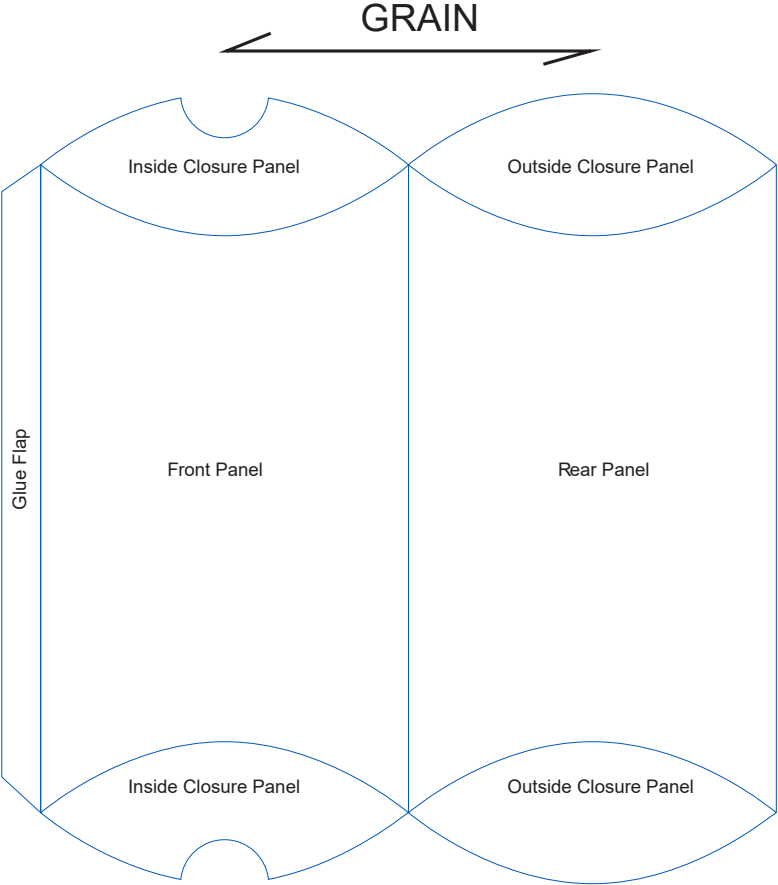
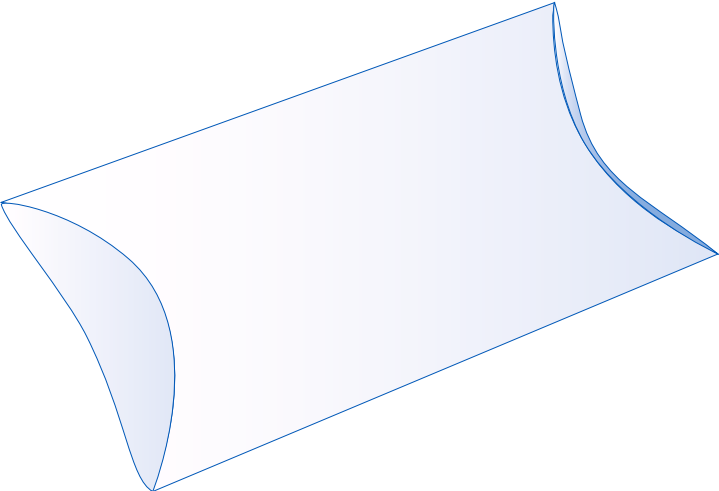

Reclosable Carton

A reclosable folding carton has at least one tamper-evident closure, which uses a lid flap with an insertion tab, a cover tab, and a cutout. The tamper-evident closure is closed by machine without the need for gluing. The tamper-evident closure can only be opened by destroying the tamper-evident closure seal. The insertion tab is constructed of at least one tear-o tab and connected by at least one predetermined break line along one edge. The first time the tamper-evident closure is opened, the insertion tab moves with the cover tab within the cut out. When the insertion tab moves beyond the breaking point at least one tear-o tab will partially tear along the first predetermined break line.

Alternatively, the cover tab is constructed of at least one second predetermined break line and a tamper-evident closure. When the reclosable folding carton is opened for the first time, the insertion tab in the cut-out of the of cover tab, moves the insertion tab beyond the breaking point. Which then causes the cover tab to partially tear along the second predetermined break line.

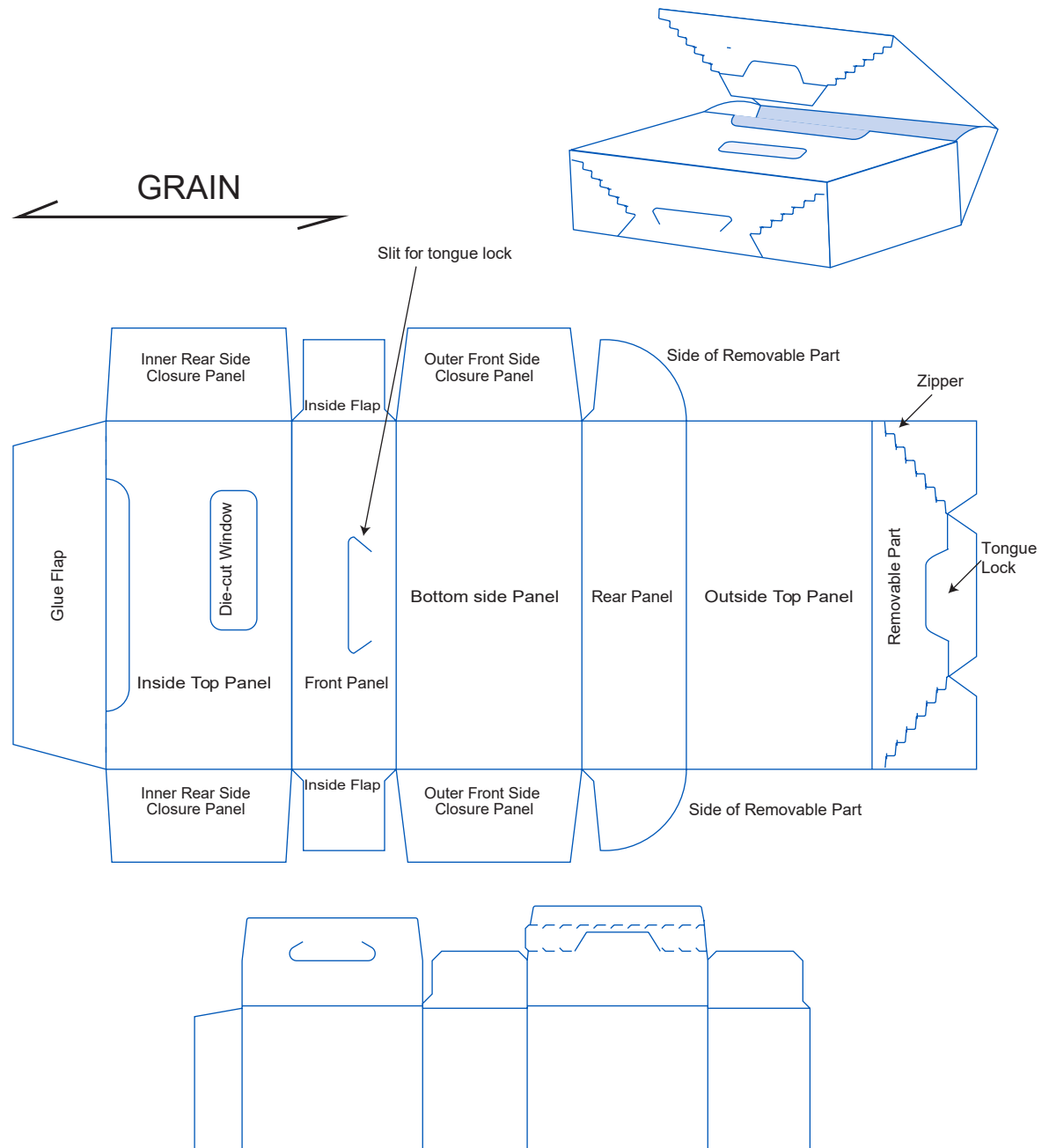

PECZUH **PRINTING & PAPERBOX**

There are a wide variety of styles and designs in folding carton. Almost everything is possible according to your imagination and especially to your needs.

The styles presented previously have one or several glue joints; however, we also offer a variety of models for instances where gluing is not part of the manufacturing process.

These cartons require a manual assembly.

This is very common for trays, cards and counter displays.

Tray Carton

The tray is often used to house a quantity of products and makes transportation easier. It can also be used as packaging, combined with a plastic film or with a lid (usually made with the same design, size adjusted to fit on top of the lower tray).

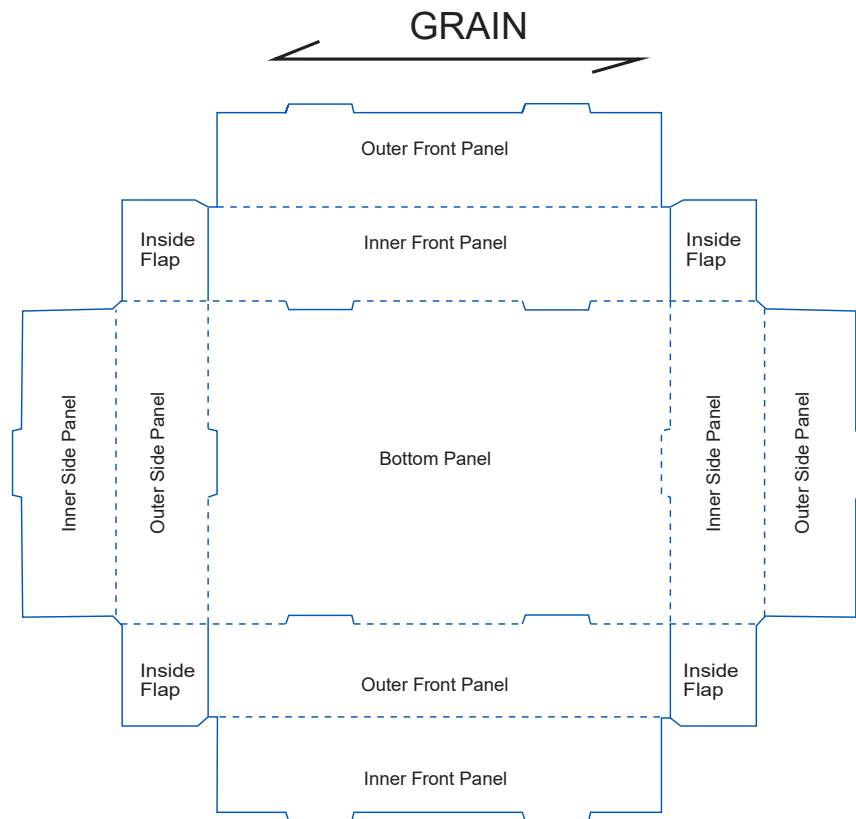
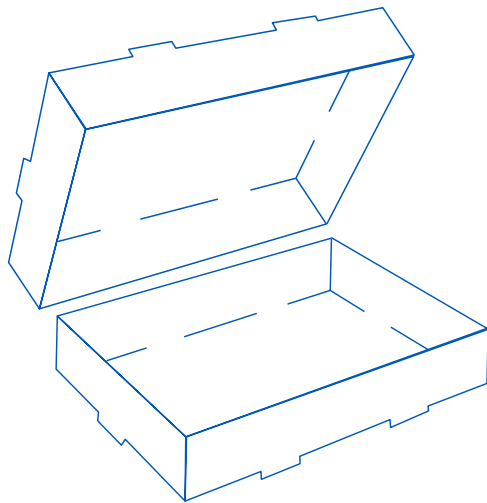

Counter Display

A Counter Display can be completely assembled manually. It does not need to be glued. Flaps as well as inner panels strengthen the structure. The cover panel (lid) will also double as a header, offering both visibility and advertising for the product.

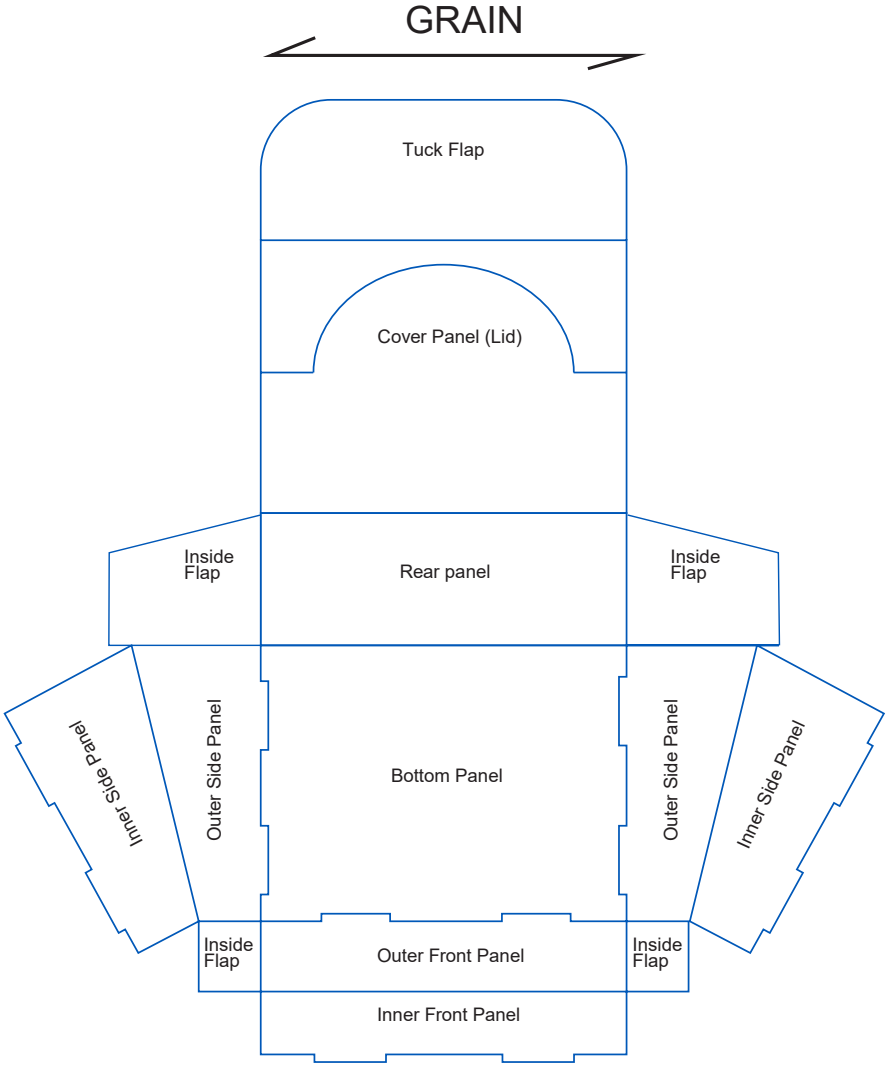
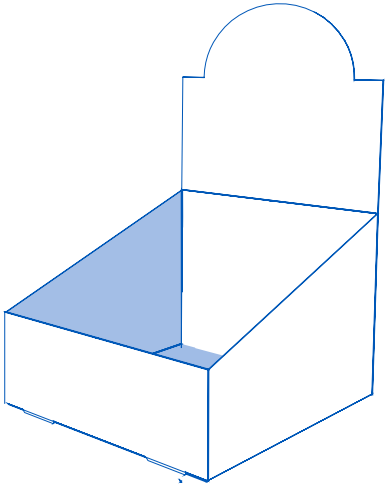

Card

The card can be an original way to present a product. It can contain, at the same time, a sample of the product as well as its description.

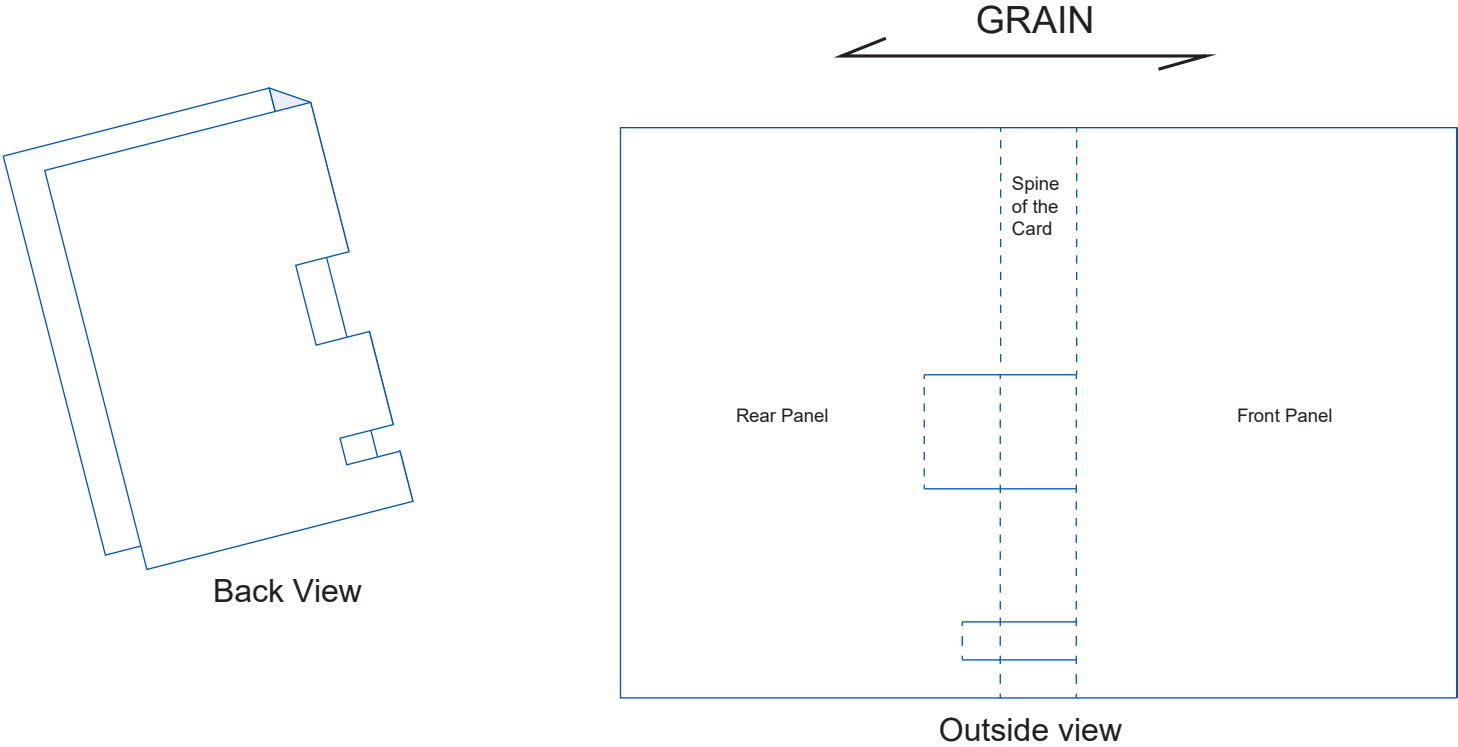

Tray

Apart from product transportation, the tray can also be made for a specific product so it will fit into a carton, reusable or not. This style of tray could also have a design where two of the sides would be glued. However, some manual assembly remains unavoidable.

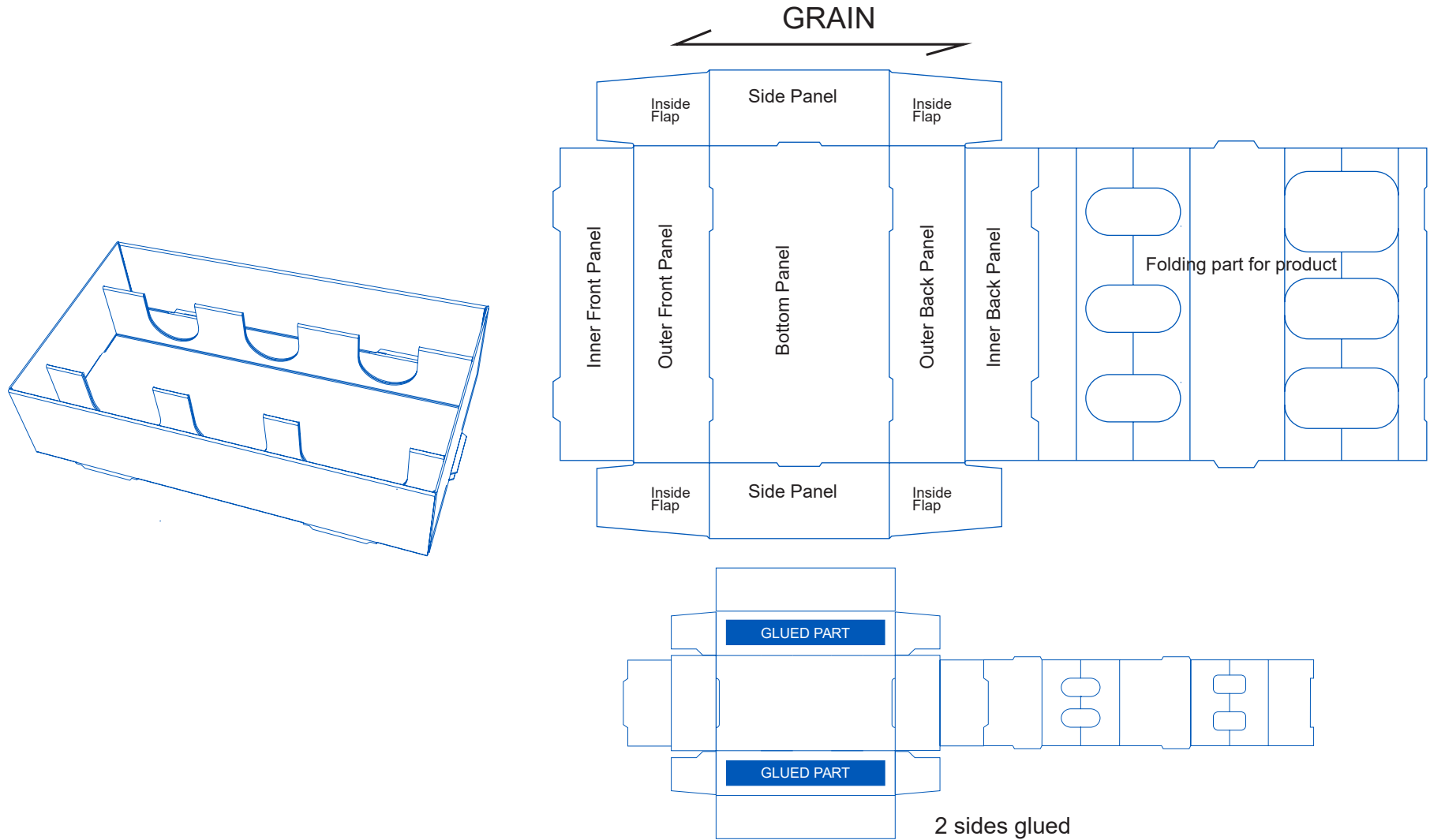

Inner Pad

An inner pad is used to protect the product. It can be used as a separator or to strengthen the carton. The example shown here, placed in a carton in the right way, will increase the strength, protect the product and will not prevent the closure of the carton.

